

Beatris Zaharia beatris.zaharia@student.tuiasi.ro

Boicu Maria-Alexandra maria-alexandra.boicu@student.tuiasi.ro

Ababei Andrei andrei.ababei@student.tuiasi.ro

Zaharia Beatris (1306A)

Ababei Andrei (1306B)

Boicu Maria-Alexandra(1305B)



Linkuri utile:

- Hackster.io: <https://www.hackster.io/beatris-zaharia/smarthome-08408e>
- Videoclip prezentare: <https://youtu.be/oRc7v3h-WTI>
- Link pentru repository github: https://github.com/AndreiAbabei-ac/SmartHome_SM_2020/tree/master

Elevator Pitch

Always put the house in your pocket with your mobile phone and be a real owner even from a distance!

Smart Home - Introduction

The purpose of the project is to automate a house, with a big influence on its security. The owner of the house will be notified via an E-mail when he/she/they has/have a guest in front of his/her/theirs house, which will contain a link towards a web page with a graphic interface and you can see using a RPI camera who is in front of your house. During the night the owner by pressing one button either the lights will go on, either lock or unlock the door. As well, they can monitor the house temperature and supervise anytime what happens in your front door.

Story

Wouldn't it be nice that when you are leaving the house to set the alarm from distance and found out who is searching for you when you are gone? Well, we developed a system for a Smart House which can do these things, plus some additional.

Let's imagine that we left to work, but we forgot to set on the alarm, then by pressing a button on the web graphic interface from a smartphone or a laptop the alarm is now activated.

But what if we are expecting guests and we are in our way back from work and the guests arrived early? With the ultrasound sensor we can detect when they are at the front door and will receive a

notification with a link to the website. From there we can open the door, turn on the lights, and check the temperature and humidity from within the house.

The system has a video camera to see who is at the front door in case you weren't expecting someone, it will take a photo and upload it to the host which can be updated whenever you want.

During the night we have additional buttons to turn on/off the lights if we need.

How it works

From the interface or command line we run the alarm script which will remain all the time active and it will wait for a person to be in its detection area. When something is detected an E-mail is sent to the owner were, he will be notified that someone is at the front door, as well a link towards the website. The sensor will have it's white LED ON all the time, while the blue one will be OFF unless something is detected then it the white LED will turn OFF and the blue LED will turn ON, as well a buzzing sound will be generated.

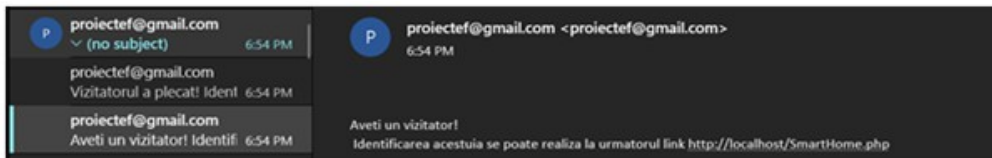

From the interface the owner will have access to different options: see who is at the front door, turn ON/OFF the lights, get a value for the house temperature, lock/unlock and close/open the door.

For each action a specific script will run, for the interface we used php and a Apache Server.

(Tutorial installing <https://www.raspberrypi.org/documentation/remote-access/web-server/apache.md>)

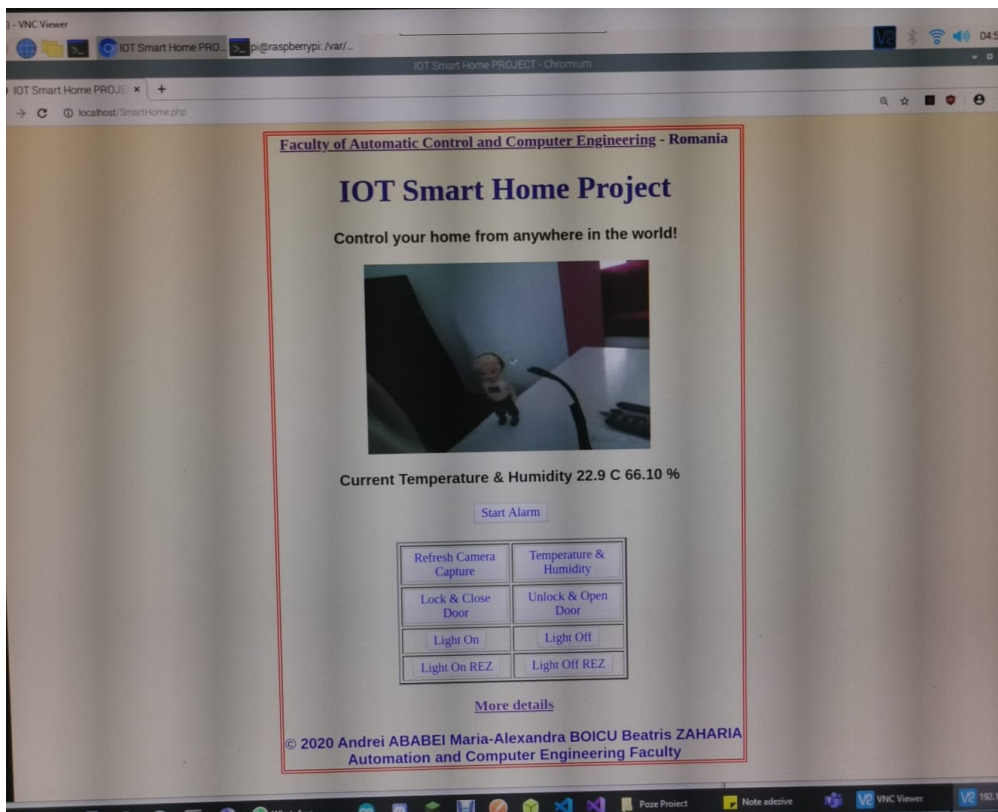

Components and applications

Software OSs and Apps:

- VNC Viewer
- PuTTY- SSH Client
- Python modules Rpi.GPIO, time, picamera, os, board, adafruit_dht, pigpio.
- Python 3.8 programming language
- Apache Server
- Raspberry Pi OS

Hardware components:

What are the requirements:

- Raspberry pi 4 model B
- 2 x servomotor
- Buzzer
- 4 x LED
- 2 x breadboard
- Ultrasonic sensor – HC-SR04
- 1N4007 – High Voltage, High Current Rated Diode

- General Purpose Transistor NPN
- Resistor 1kohm
- ~20 x Male/Male Jumper Wires
- ~20 x Male/Female Jumper Wires
- ~20 x Female/Female Jumper Wires
- RPI Camera V3
- 6 x LED from an old lamp or 6 x normal LED
- 9 x Through Hole Resistor, 150 ohm
- 2 x external batteries (output 5V)
- 1 x AM2302 (wired DHT22) temperature-humidity sensor
- 2 x Arduino UNO R3
- Carboard box
- Logistics
- Thumbtack
- Optional: dolls

Photos

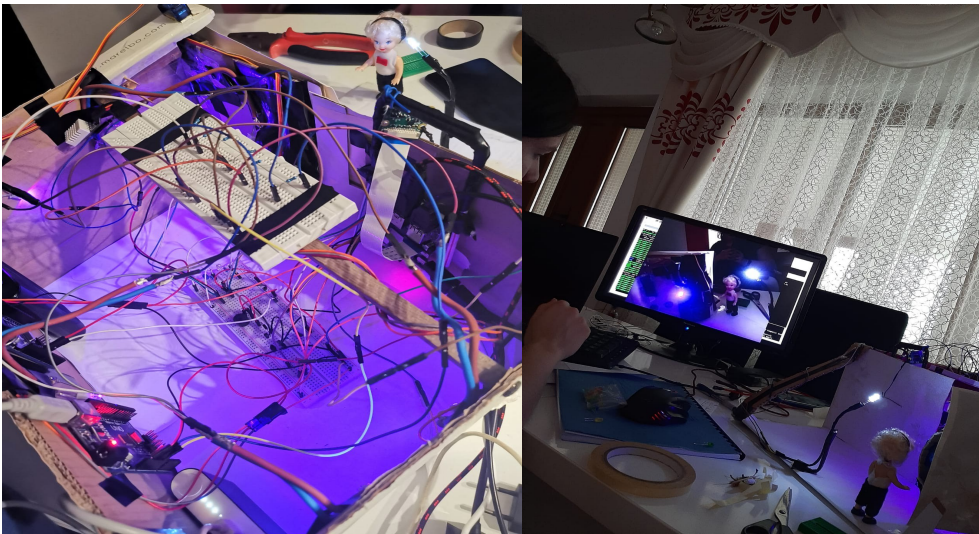

For more photos access the link: <https://myalbum.com/album/VUKjsgdR5aPW>

Usage of Pins

GPIO pins

- Pin 13 -> actuates the servomotor to open/close the door
- Pin 17 -> actuates the servomotor to lock/unlock the door
- Pin 27 -> controls the white LED from the front of the house
- Pin 10 -> controls a green LED (redundancy)
- Pin 18 -> controls the buzzer
- Pin 4 -> controls the temperature and humidity sensor
- Pin 12 (trigger) & Pin 20 (echo) -> controls the ultrasonic sensor

- Pin 14 -> controls the blue LED (visitor inbound)
- Pin 15 -> controls the white LED (active alarm)

Physical pins

- 3v3 -> (VCC) humidity sensor
- Pin 2 (5v Power) -> power everything connected to the breadboard
- Pin 9 (Ground) -> connected to the breadboard

Schematics

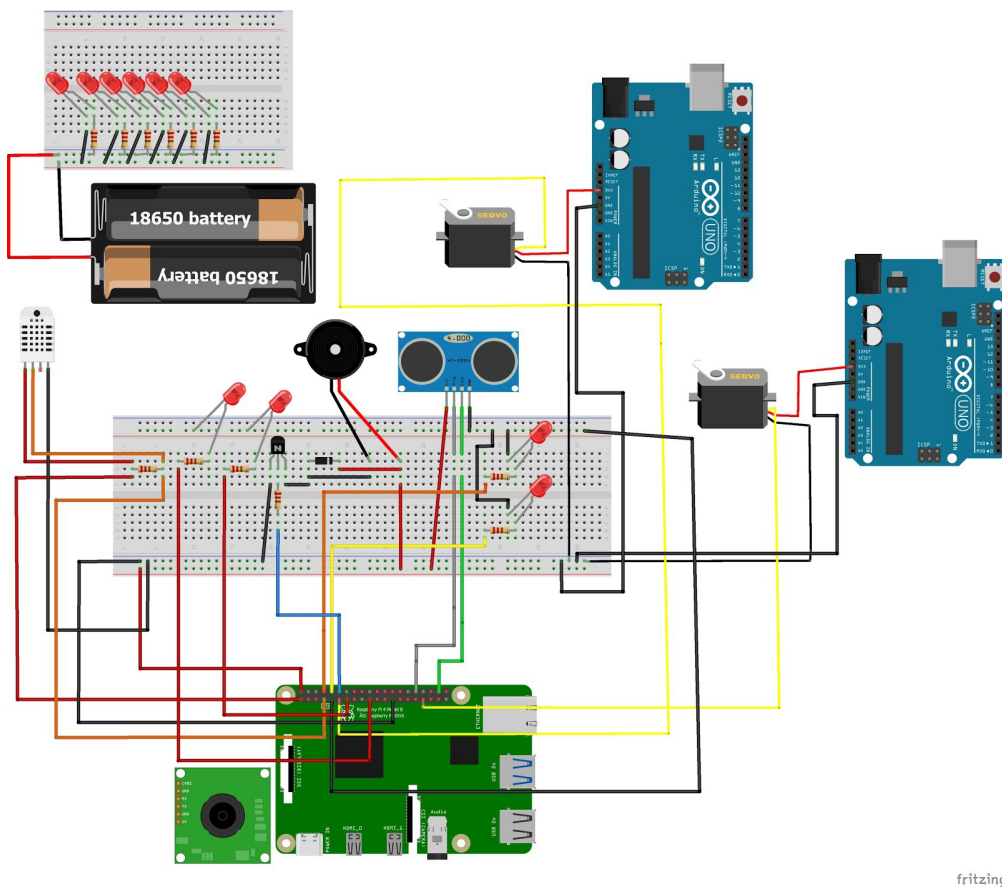

Nota

Acest document constituie un rezumat al documentatiei de baza care se gaseste pe Hackster.io: <https://www.hackster.io/beatrix-zaharia/smarthome-08408e> respectiv in fisierul README de pe github https://github.com/AndreiAbabei-ac/SmartHome_SM_2020/tree/master